

Lincat



PANTHER Hot Cupboards



Quality built on experience

With a catering equipment manufacturing heritage that spans five decades, Lincat has built a reputation for quality and innovation. Our continued success both in the UK and overseas owes everything to a simple yet fundamental principle - we listen to our customers. As a result, we have developed an in-depth understanding of our customers' needs for reliability, consistency and efficiency.

To ensure we meet those needs we have invested heavily in the latest production techniques and a highly skilled product design and food application team. We source only the best quality materials and components. And we set ourselves the highest standards in the industry. All of which is reflected in well designed, superbly built products that combine innovative features with proven technology, backed by first class customer service and technical support.

Contents	Pages
800 Series	4-9
670 Series	10-15
Accessories	16
Light Duty Series	17
Dimensions	18-19



PANTHER

Hot cupboards that cater for every need

Whether you serve relatively small numbers or hundreds of diners every day, catering is a demanding environment. And that demands equipment that is built for the challenge. Panther hot cupboards are not only designed to provide outstanding functionality and flexibility, they are manufactured by Lincat to the highest specifications. Robust, hygienic, and highly energy-efficient, Panther hot cupboards are the professionals' choice.

The Panther range is extensive. The 800 Series and the 670 Series are both available in various lengths. The 800 Series can accommodate between three and six standard 1/1 GN containers, whilst the 670 Series can hold as many as five. Incorporating great value-added features as standard such as digital temperature display and control, fan assisted heating and 1/1 GN compatible mirror stainless steel

interiors, both series offer a choice of plain or bain marie tops. You can also choose between static models with sturdy, adjustable legs or mobile units with castors and push bar. So whether you need to transport food, form a servery or create a kitchen pass, Panther offers the ideal solution.

In addition to the 800 and 670 Series, the Light Duty series comprises four static models that are ideal for holding food and warming plates.

From cafeterias to large restaurants, small care homes to hospitals, primary schools to colleges and universities, the Panther range of hot cupboards more than measures up to the task.



Unrivalled choice with capacity to match

Panther 800 Series hot cupboards combine attractive, practical, energy-saving design with the capacity and quality essential for holding and transporting food at the desired temperature in high volumes. This range comprises plain top and bain marie models at 800mm deep and 900mm high in a choice of four lengths. The bain marie versions can accommodate up to six 1/1 GN containers.

Features such as fan-assisted heating and accurate digital thermostatic control deliver exceptional energy-efficiency. And with a wide range of options including tray slides, corner bumpers, door locks plus an extensive range of overshelves, you can 'tailor' your 800 Series hot cupboards to suit your specific needs.

Ideal for large restaurants, hospitals, schools and cafeterias, Panther 800 Series hot cupboards are remarkably versatile. Supplied as mobile units (static versions optional), you can specify them as 'pass through' models with a set of sliding doors either side of the fully 1/1 GN compatible hot cupboard.



Robust, reliable and high capacity



All 800 Series models are available as pass through versions



Hot cupboard will accept 1/1GN containers



Accurate digital electronic temperature control as standard



Easily removable doors



Supplied with two heavy duty multi-section chrome plated shelves

Features

- Choice of static and mobile versions
 - Static - with sturdy, adjustable legs
 - Mobile - with a push bar and robust 100mm diameter heavy duty swivel and braked castors
- Fully 1/1GN compatible hot cupboard for operational efficiency
- Fan assisted hot cupboard provides even heat distribution, fast heat up and recovery times, and lower energy usage
- Supplied with two heavy duty multi-section chrome plated rod shelves capable of taking the heaviest loads
- Four shelf positions allow adjustment to meet individual needs
- Accurate digital electronic control of the hot cupboard temperature, adjustable between 20 and 99°C, ensures compliance with food hygiene regulations
- Double skinned construction provides efficient heat retention and a cool to touch exterior – safe and energy-efficient
- Removable doors and shelves allow access to the fully stainless steel interior for easy cleaning
- Easy-fit robust push bar supplied with mobile units can be fitted to either end of the hot cupboard
- Optional pass through models with removable sliding doors to both sides provide enhanced workflow efficiencies
- Streamlined design allows units to be suited together and sit flush against walls
- Multi-panel base construction provides extra rigidity



Convenient plating area



Upturned edge for easy removal of GN containers



Internal tap with tube for easy draining



A range of sizes and accessories gives unparalleled versatility

Bain marie models

- Units available to take 3,4,5 or 6 x 1/1 GN containers up to 150mm deep
- Thermostatically controlled bain marie top can be operated with wet or dry heat
- Convenient plating area
- Uprturned rim of bain marie well allows easy removal of gastronorm containers
- Drain tap located inside hot cupboard allows fast and easy draining
- Easy to clean flat bottom tank of bain marie section



Adjustable leg option
All 800 Series models are available as static or mobile versions

Plain top models

- Sturdy stainless steel top – ideal for plating and garnishing and for use as a mobile workstation



Adjustable leg option
All 800 Series models are available as static or mobile versions



800 Series Bain Marie Models

Model	No of 1/1GN Containers for BM Well	External Height (mm)	External Width (mm)	External Depth (mm)	Internal Height (mm)	Internal Width (mm)	Internal Depth (mm)	Weight (kg)	Doors Both Sides	Plate Meal Capacity	No of 10" Plates	Power (kW)	Amps at 230V
P8B3	3	900	1125	800	440	1020	640	104	X	45	316	2.8	12.4
P8B4	4	900	1450	800	440	1345	640	125	X	57	396	4.9	21.5
P8B5	5	900	1775	800	440	1670	640	146	X	69	476	5.2	22.6
P8B6	6	900	2100	800	440	1995	640	166	X	81	556	5.2	22.6
P8B3PT	3	900	1125	800	440	1020	640	106	✓	45	316	2.8	12.4
P8B4PT	4	900	1450	800	440	1345	640	127	✓	57	396	4.9	21.5
P8B5PT	5	900	1775	800	440	1670	640	148	✓	69	476	5.2	22.6
P8B6PT	6	900	2100	800	440	1995	640	168	✓	81	556	5.2	22.6

PT = Pass through models.

800 Series Plain Top Models

Model	External Height (mm)	External Width (mm)	External Depth (mm)	Internal Height (mm)	Internal Width (mm)	Internal Depth (mm)	Weight (kg)	Doors Both Sides	Plate Meal Capacity	No of 10" Plates	Power (kW)	Amps at 230V
P8P3	900	1125	800	440	1020	640	92	X	48	316	1.5	6.5
P8P4	900	1450	800	440	1345	640	114	X	60	396	2.5	10.9
P8P5	900	1775	800	440	1670	640	136	X	72	476	2.5	10.9
P8P6	900	2100	800	440	1995	640	158	X	84	556	2.5	10.9
P8P3PT	900	1125	800	440	1020	640	94	✓	48	316	1.5	6.5
P8P4PT	900	1450	800	440	1345	640	116	✓	60	396	2.5	10.9
P8P5PT	900	1775	800	440	1670	640	138	✓	72	476	2.5	10.9
P8P6PT	900	2100	800	440	1995	640	160	✓	84	556	2.5	10.9

PT = Pass through models.

Flexibility and function above all

One of the many optional accessories available with Panther 800 Series hot cupboards, overshelves make a very useful and cost-effective addition.

There are no fewer than six 800 Series overshelf units to choose from for each hot cupboard. The range comprises single, double and triple tiered overshelves, each available as an ambient unit or fitted with quartz heat lamps, which are controlled independently of the hot cupboard itself.

Ideal for short-term holding of plated meals or for creating an efficient, high capacity kitchen pass, these sturdy overshelves not only look the part, they play their part in a professionally run kitchen. Panther overshelves – the perfect way to top off your 800 Series hot cupboards installation.

800 Series Overshelves

Model	Heated or Ambient	No of Shelves	To fit Model*	Height (mm)	Width (mm)	Depth (mm)	Weight (kg)	Power (kW)	Amps at 230V
PS83A1	A	1	P8B3, P8P3	325	1125	320	7	N/A	N/A
PS84A1	A	1	P8B4, P8P4	325	1450	320	9	N/A	N/A
PS85A1	A	1	P8B5, P8P5	325	1775	320	11	N/A	N/A
PS86A1	A	1	P8B6, P8P6	325	2100	320	13	N/A	N/A
PS83A2	A	2	P8B3, P8P3	615	1125	320	14	N/A	N/A
PS84A2	A	2	P8B4, P8P4	615	1450	320	18	N/A	N/A
PS85A2	A	2	P8B5, P8P5	615	1775	320	22	N/A	N/A
PS86A2	A	2	P8B6, P8P6	615	2100	320	26	N/A	N/A
PS83A3	A	3	P8B3, P8P3	905	1125	320	21	N/A	N/A
PS84A3	A	3	P8B4, P8P4	905	1450	320	27	N/A	N/A
PS85A3	A	3	P8B5, P8P5	905	1775	320	33	N/A	N/A
PS86A3	A	3	P8B6, P8P6	905	2100	320	39	N/A	N/A
PS83H1	H	1	P8B3, P8P3	325	1125	320	10	0.6	2.6
PS84H1	H	1	P8B4, P8P4	325	1450	320	13	0.8	3.5
PS85H1	H	1	P8B5, P8P5	325	1775	320	16	1	4.3
PS86H1	H	1	P8B6, P8P6	325	2100	320	19	1.2	5.2
PS83H2	H	2	P8B3, P8P3	615	1125	320	20	1.2	7.8
PS84H2	H	2	P8B4, P8P4	615	1450	320	26	1.6	5.2
PS85H2	H	2	P8B5, P8P5	615	1775	320	32	2	6.9
PS86H2	H	2	P8B6, P8P6	615	2100	320	38	2.4	10.4
PS83H3	H	3	P8B3, P8P3	905	1125	320	27	1.8	7.8
PS84H3	H	3	P8B4, P8P4	905	1450	320	35	2.4	10.4
PS85H3	H	3	P8B5, P8P5	905	1775	320	48	3	13
PS86H3	H	3	P8B6, P8P6	905	2100	320	57	3.6	15.7

* Also available with pass through models.



Heated



Ambient

Panther 800 Series overshelves are available as heated units with quartz lamps, or as ambient models.



Single-tier overshelf



Two-tier overshelf



Three-tier overshelf

Quality and choice made even more accessible

At 670mm deep, Panther 670 Series hot cupboards are designed to fit through narrow doorways. This makes them ideal for pubs and smaller restaurants as well as nursing and care homes where plated meals are to be transported from the kitchen to the residents.

Although physically smaller than the 800 Series, the 670 Series is big on features and generous on capacity. The range offers a choice of bain marie or plain top units each in four different lengths standing 900mm high. Bain marie models can accommodate up to five 1/1 GN containers.

You'll save on energy costs too. The highly efficient Panther 670 Series achieves a 25% reduction in electricity usage compared with its predecessor.

Available as mobile or static units, all 670 hot cupboards are fan assisted and fully 1/1 GN compatible. Options include a choice of stylish gantries and different colours for the front panels.



Capable of holding 1/1GN containers



Internal tap with tube for easy draining



An array of optional accessories is available including stylish gantries and tray slides

Features

- Choice of static and mobile versions
 - Static - with sturdy, adjustable legs
 - Mobile - with a push bar and robust 100mm diameter heavy duty swivel and braked castors
- Fully 1/1GN compatible hot cupboard for operational efficiency
- Fan assisted hot cupboard provides even heat distribution, fast heat up and recovery times, and lower energy usage
- Supplied with two heavy duty multi-section chrome plated rod shelves capable of taking the heaviest loads
- Four shelf positions allow adjustment to meet individual needs
- Accurate digital electronic control of the hot cupboard temperature, adjustable between 20 and 99°C, ensures compliance with food hygiene regulations
- Double skinned construction provides efficient heat retention and a cool to touch exterior – safe and energy-efficient
- 670mm depth allows access through narrow door openings
- Removable doors and shelves allow access to the fully stainless steel interior for easy cleaning
- Easy-fit robust push bar supplied with mobile units can be fitted to either end of the hot cupboard
- Streamlined design allows units to be suited together and sit flush against walls
- Multi-panel base construction provides extra rigidity



Supplied with two heavy duty multi-section chrome plated shelves



Upturned edge for easy removal of GN containers



Accurate digital electronic control as standard



Robust design and high capacity

Bain marie models

- Units available to take 2,3,4 or 5 x 1/1 GN containers up to 150mm deep
- Thermostatically controlled bain marie top can be operated with wet or dry heat
- Upturned rim of bain marie well allows easy removal of gastronorm containers
- Drain tap located inside hot cupboard allows fast and easy draining
- Easy to clean flat bottom tank of bain marie section



Adjustable leg option
All 670 Series models are available as static or mobile versions

Plain top models

- Sturdy stainless steel top – ideal for plating and garnishing and for use as a mobile workstation



Adjustable leg option
All 670 Series models are available as static or mobile versions



P6B5



P6B4



P6B3



P6B2



P6P2



P6P3



P6P4



P6P5

670 Series Bain Marie Models

Model	No of 1/1GN Containers for BM Well	External Height (mm)	External Width (mm)	External Depth (mm)	Internal Height (mm)	Internal Width (mm)	Internal Depth (mm)	Weight (kg)	Plate Meal Capacity	No of 10" Plates	Power (kW)	Amps at 230V
P6B2	2	900	900	670	440	820	540	80	33	222	2.6	11.3
P6B3	3	900	1125	670	440	1020	540	95	45	302	2.8	12.4
P6B4	4	900	1450	670	440	1345	540	116	57	382	4.9	21.5
P6B5	5	900	1775	670	440	1670	540	136	69	462	5.2	22.6

670 Series Plain Top Models

Model	External Height (mm)	External Width (mm)	External Depth (mm)	Internal Height (mm)	Internal Width (mm)	Internal Depth (mm)	Weight (kg)	Plate Meal Capacity	No of 10" Plates	Power (kW)	Amps at 230V
P6P2	900	900	670	440	820	540	71	36	236	1.5	6.5
P6P3	900	1125	670	440	1020	540	86	48	316	1.5	6.5
P6P4	900	1450	670	440	1345	540	105	60	396	2.5	10.9
P6P5	900	1775	670	440	1670	540	124	72	476	2.5	10.9

Hygienic food service with style

All 670 Series hot cupboards are available with optional gantries, either as ambient units or fitted with quartz heat lamps to provide additional heat and illumination. Sleek and stylish, the curved profile incorporates a glass sneeze screen, helping you to maintain excellent standards of hygiene.

Perfectly suited for use in carveries and buffet operations, the 670 Series gantry not only protects food items in the bain marie, it can help protect your reputation too.

As well as supporting good practice in food service hygiene, the 670 Series gantries can make an attractive contribution to the quality of your food presentation and enhance its appeal.



Heated

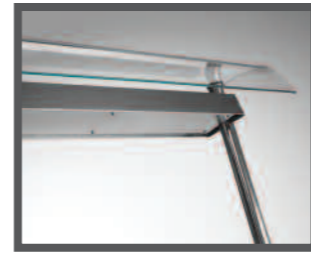

Ambient

Panther 670 Series gantries are available as heated units with quartz lamps, or as ambient models

670 Series Gantries

Model	Heated or Ambient	To fit Model	Height (mm)	Width (mm)	Depth (mm)	Weight (kg)	Power (kW)	Amps at 230V
PG62A	A	P6B2, P6P2	520	900	460	9	N/A	N/A
PG63A	A	P6B3, P6P3	520	1125	460	12	N/A	N/A
PG64A	A	P6B4, P6P4	520	1450	460	16	N/A	N/A
PG65A	A	P6B5, P6P5	520	1775	460	20	N/A	N/A
PG62H	H	P6B2, P6P2	520	900	460	9	0.4	1.7
PG63H	H	P6B3, P6P3	520	1125	460	12	0.6	2.6
PG64H	H	P6B4, P6P4	520	1450	460	16	0.8	3.5
PG65H	H	P6B5, P6P5	520	1775	460	20	1	4.3



670 Series Colour options

Be a shade more adventurous

Here's a striking way to transform the look of your 670 Series hot cupboards and brighten-up your food service area at the same time.

All 670 Series hot cupboards can be specified with the option of four different colours for the front panels. Choose from a warm radiant red, a fresh zestful yellow, a cool calming blue, or a relaxing natural green.

Brilliant for coordinating open kitchens with dining area colour schemes, creating a unique identity or energising the ambience of your establishment, these colour options are perfect for schools, colleges and any dining environment that dares to be a shade different.



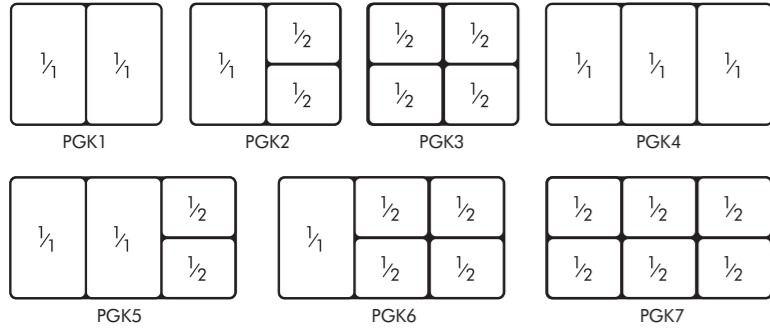

Gastronorm packs

Packs of 150mm deep gastronorm containers can be specified at favourable prices.

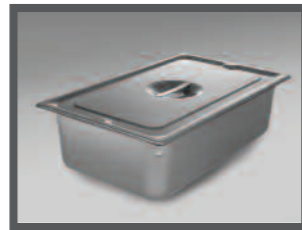

800 & 670 Series Options and Accessories

Model	Description	Height	Width	Depth	800 Series								670 Series										
					P8B3	P8B4	P8B5	P8B6	P8P3	P8P4	P8P5	P8P6	P6B2	P6B3	P6B4	P6B5	P6P2	P6P3	P6P4	P6P5			
PTS2	Tray Slide	25	900	320																			
PTS3	Tray Slide	25	1125	320	•					•													
PTS4	Tray Slide	25	1450	320		•					•												
PTS5	Tray Slide	25	1775	320				•															
PTS6	Tray Slide	25	2100	320					•														
PDL	Door Lock	N/A	N/A	N/A	•	•	•	•	•	•	•	•	•	•	•	•	•	•	•	•	•	•	•
PCG	Corner Bumpers	25	110	25	•	•	•	•	•	•	•	•	•	•	•	•	•	•	•	•	•	•	•
PPB6	Additional Push Bar	30	670	80																			
PPB8	Additional Push Bar	30	800	80	•	•	•	•	•	•	•	•	•	•	•	•	•	•	•	•	•	•	•
CP16	Carvery Pad	30	325	530	•	•	•	•	•														
PHTC	1/1 GN Ceramic Panel Insert	10	325	530	•	•	•	•															
PHTG	1/1 GN Glass Panel Insert	10	325	530	•	•	•	•															
	Front panel colour options	N/A	N/A	N/A																			
	Gastronorm packs	N/A	N/A	N/A	•	•	•	•															



Drop down tray slide



Door lock



Corner bumpers

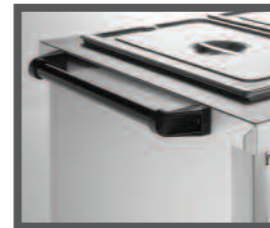

Additional push bar

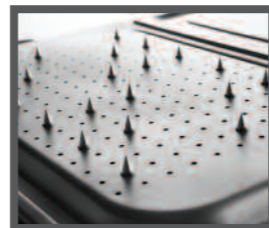

Carvery pad

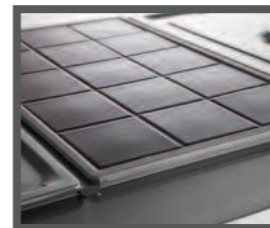

Ceramic panel insert



Glass panel insert

Light Duty Series

A compact solution without compromise

Don't let the name fool you. The Light Duty series shares the same top quality build standards for which the Panther range and the Lincat brand are so highly respected among catering professionals everywhere.

These popular static hot cupboards are the units of choice for smaller establishments where space is at a premium or where budgets are tight. Although relatively compact in size,

Panther Light Duty Series hot cupboards are ideal for warming plates and for holding food safely and effectively at the desired temperatures.

Adjustable and accurate thermostatic control is standard and all units are supplied with three chrome plated shelves.

Features

- Fully insulated for enhanced energy-efficiency
- Adjustable thermostatic control to meet food safety regulations
- Compact, space saving design
- Ideal for food holding and for use as a plate warmer



PLH36



PLH45



PLH60



PLH90

Light Duty Series

Model	External Height (mm)	External Width (mm)	External Depth (mm)	Internal Height (mm)	Internal Width (mm)	Internal Depth (mm)	Weight (kg)	Plate Meal Capacity	No of 10" Plates	Power (kW)	Amps at 230V
PLH36	900	360	600	690	315	540	28	22	150	0.75	3.2
PLH45	900	450	600	690	400	540	37	22	150	0.75	3.2
PLH60	900	600	600	690	550	540	45	44	240	1.5	6.3
PLH90	900	900	600	690	850	540	61	66	360	2	8.4



Adjustable temperature control

PANTHER 800 Series

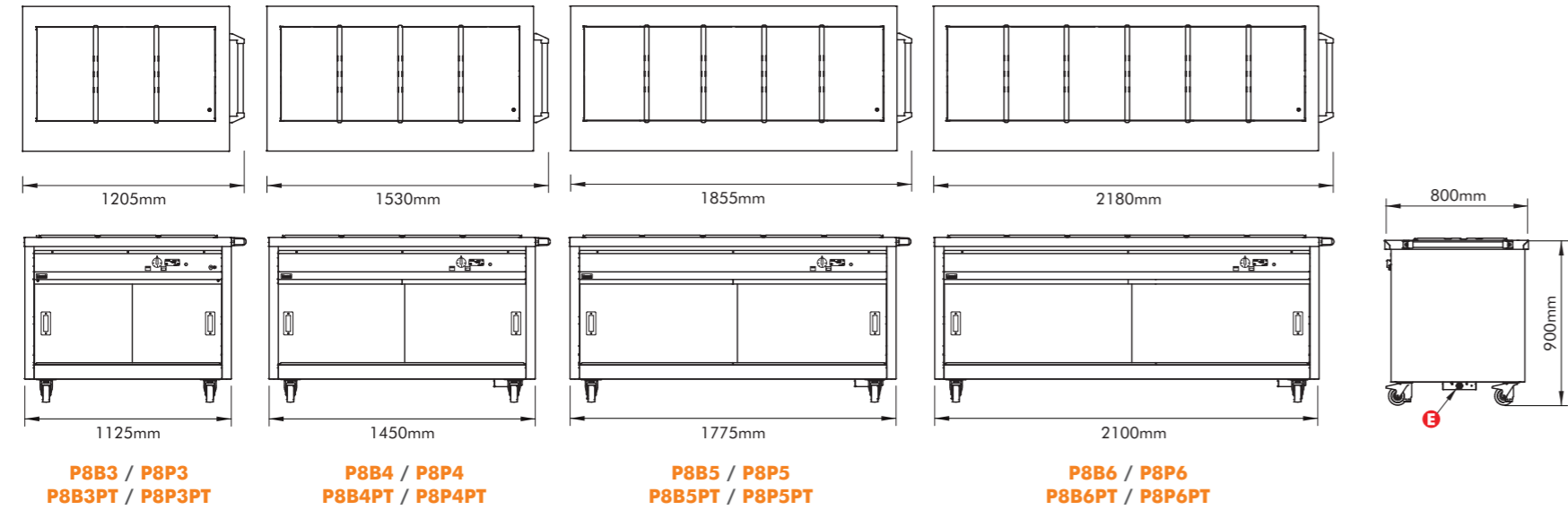

PANTHER Light Duty Series

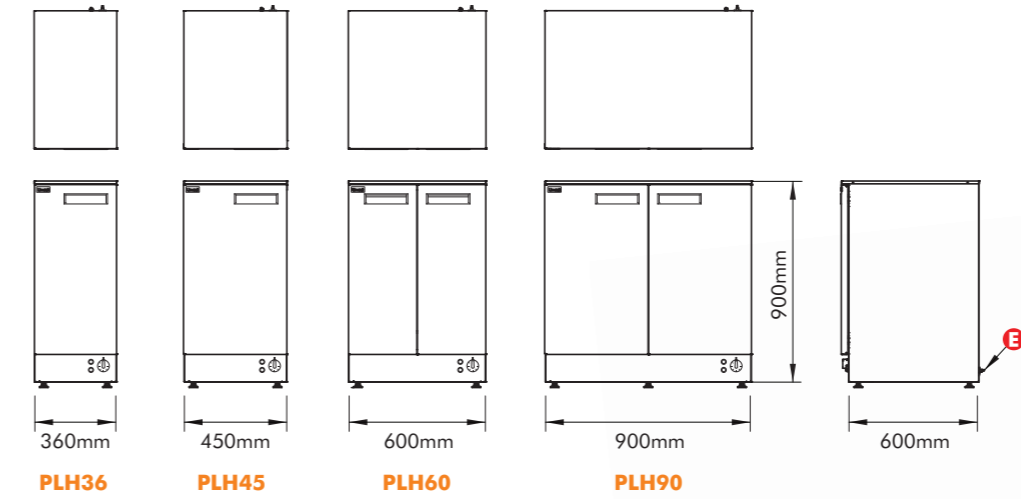

PANTHER 670 Series

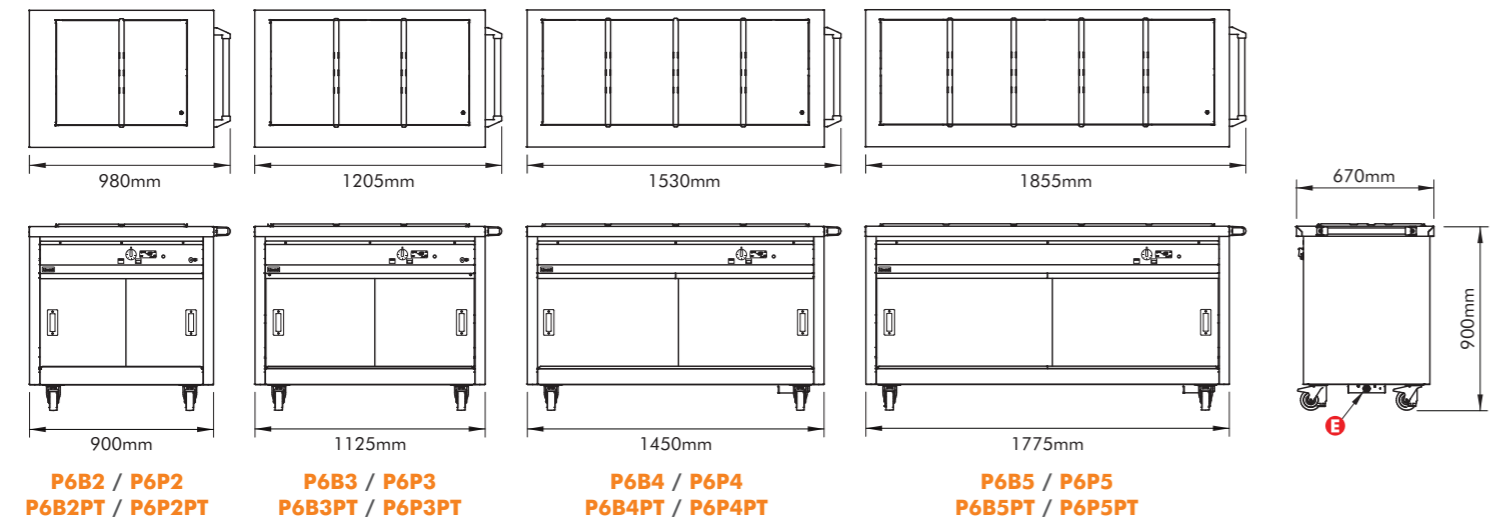

Quality Guaranteed

You can choose Lincat products with total confidence. All Lincat Panther products are backed by the reassurance of a comprehensive UK twelve-month warranty. It is nothing less than you would expect from Lincat - a company with a long track record as one of Europe's largest and most successful manufacturers of catering equipment.



Lincat is approved by Lloyds Register of Quality Assurance for its quality management systems

A member company of  **THE MIDDLEBY CORPORATION**

Distributed by:



**Lincat Limited, Whisby Road,
Lincoln LN6 3QZ,
United Kingdom**

Sales Tel: 01522 875500 Spares Tel: 01522 875510 General Tel: 01522 875555
Fax: 01522 875530 International Sales Tel: +44 1522 503250 International Fax: +44 1522 875530
Website: www.lincat.co.uk e-mail: sales@lincat.co.uk International e-mail: export@lincat.co.uk

